

## Elephant BETA electric chain hoist



The Elephant Beta 230 VAC electric chain hoists are light weight, compact and ideal for light installation work.

### Properties

- Slip clutch for overload prevention
- Self-locking brake that will hold the load at any required height
- Very low own weight, only 7.5 kg.
- Very compact.
- In case of overload, the hooks will gradually bend and do not suddenly break off.
- Grade 10 load chain.

### Technical specification:

- Insulation class B.
- FEM 9.511 motor: 1Am.
- Power supply 230VAC.
- Protection class IP54
- Control power supply 230VAC direct control.

### Standard delivery

- 3 m lifting height (maximum distance between top and bottom hook).
- 1.8 m control cable, direct control.
- 3 m power cable.
- Chain bag max 10 m.
- Exclusive trolley.

### Option

- Other hoisting and operating height is also possible.
- Push trolley.

### Norm:

- EN12100-1/2, EN818-7, EN14492

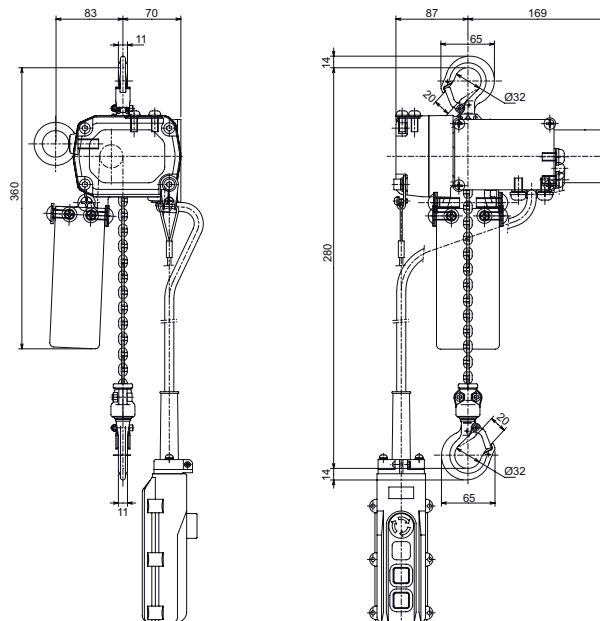

Only weighs  
**7,5 kg**  
3m lifting height

Type	WLL (kg)	Lifting speed (m/min)	Duty cycle sw/h (%)	Load chain (mm)	Number of falls	Max. lifting height (m)	Construction height (mm)	Power (kW)	Weight (kg)	ProductId
BETA-H/125KG	125	6.5	150 (25)	3 x 9	1	10	280	0.18	7.5	0511001
BETA-H/200KG	200	3.8	150 (25)	3 x 9	1	10	280	0.18	7.5	0511003